

Swap system „Wechselsystem WS 120 Einzel“ (hot-dip galvanised steel)



- > **scope of delivery:** 2 crossbars with guide roller holder, front stop fixed or collapsible, 2 clearance beams, 8 inner part kits, fastening material such as brackets, clamping plates, reinforcement plates, flange head screws and lock nuts
- > **hight adjustment:** 120 mm
- > **system hight:** 120 | 160 mm
- > **parking levels:** 1,020 - 1,220 | 1,120 – 1,320 mm *(depending on chassis design and system height)*
- > **swap body sizes:** C 715 , C 745 , C 782

possible chassis:

- > Mercedes: Actros, Antos
- > MAN TGX, MAN TGM
- > DAF XF, Scania R, Iveco S-Way
- > Volvo FH with 266 mm and 300 mm longitudinal beam
- > Renault T with 266 mm and 300 mm longitudinal beam

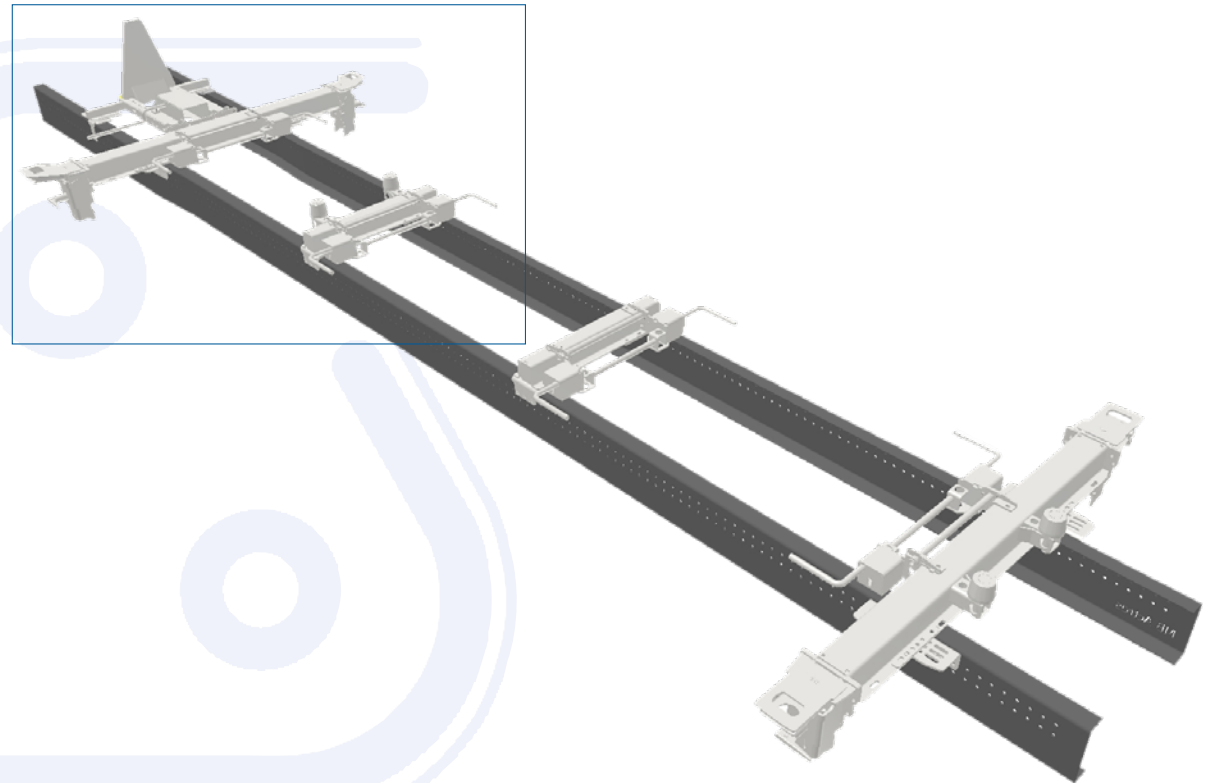
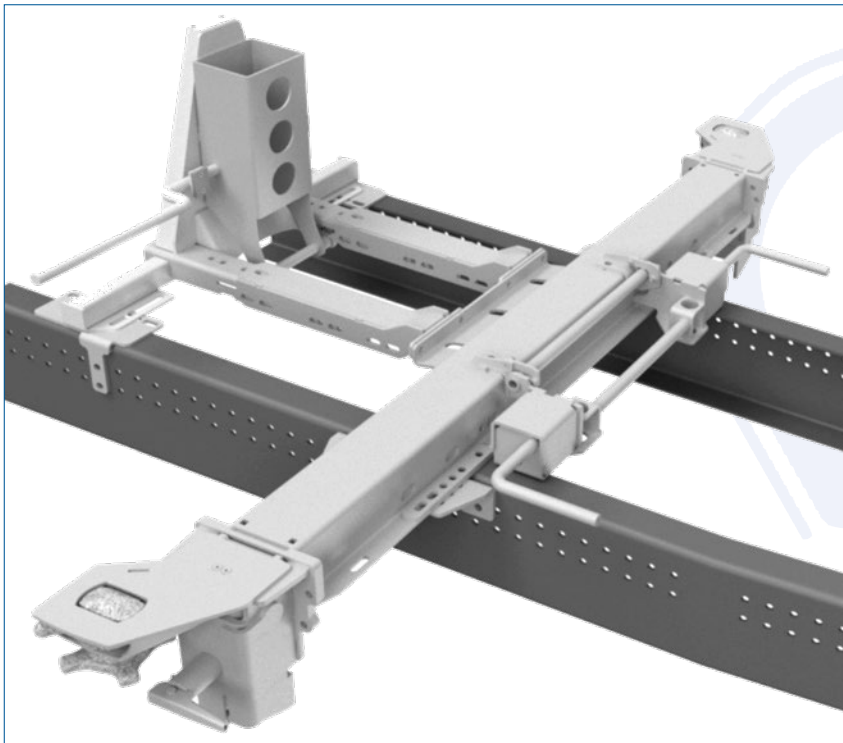

A more detailed description of this swap system can be found in the respective assembly instructions.