

Swap body bolster rigid 335 x 85

- > steel raw
- > for C745 / C782
- > 2 twist locks on each side (*inner parts 410.075.620*)
- > **with two guide rollers**, with welded holder for guide rollers
- > bolster 85 mm high
- > weight 123 kg

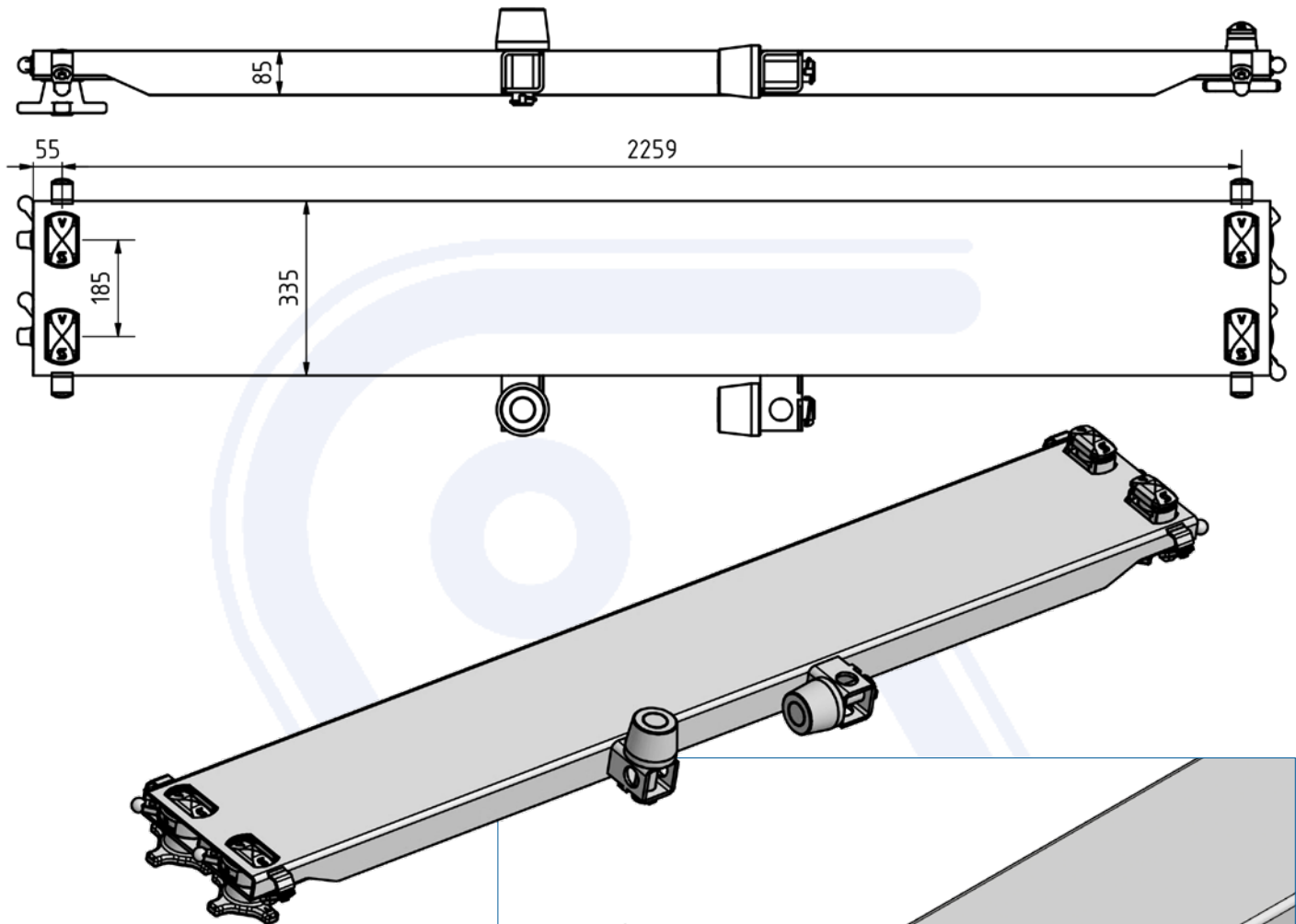

Art.-No. 410.077.700



Pos.	Spare part	Art.-No.
1	Bolster	410.076.102
2	Locking pin	906.000.276
3	Security ring	905.000.187
4	Locking pin guide	906.000.273
5	Outer guide	906.000.274
6	Locking nut	906.000.275
7	Holder f. security latch	905.159.006
8	Security latch	905.159.005
9	Washer	906.036.005
10	Screw	020.008.016
11	Holder f. guide roller	640.003.005
12	Guide roller /85	640.003.110
13	Folding pin	640.003.112

