

# NEWS



Rapid information for our customer

## Steel /stainless steel rear frames: Sealed with ease!

Our aluminium rear frame kits feature integrated seals to close the gap between the body and tail lift. Previously, seals **for steel and stainless steel frames** had to be fitted manually, which was a time-consuming process. **Factory-fitted seals** are now available for more efficient installation.



### High-quality EPDM sealing system



- > **high elastic recovery** over repeated opening cycles
- > resistant to UV light, ozone, cleaning agents, etc.
- > **remains flexible from - 40 °C to + 120 °C**
- > designed for a **24 mm application thickness**

### Pre-assembled for efficient production

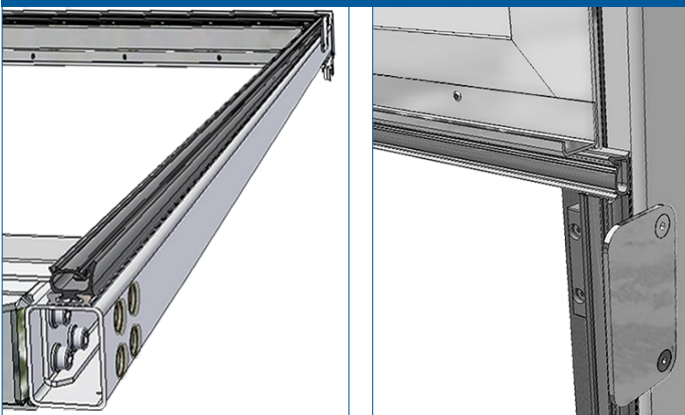

- > the sealing system **includes a stop fitted at the lower end of the rear frame** for system integration
- > **shorter lead times**
- > time saved = **lower costs**
- > easy **seal replacement** in the aluminium profile during service



**AluTeam Fahrzeugtechnik GmbH**  
 Brockhagener Straße 88, D-33649 Bielefeld  
 ☎ +49 (0) 521 - 41 73 11 - 0  
 ✉ info@aluteam.de 🌐 www.aluteam.de

**AluTeam Fahrzeugtechnik Wolfhagen GmbH**  
 Hans-Böckler-Straße 4, D-34466 Wolfhagen  
 ☎ + 49 (0) 56 92 - 609 - 0  
 ✉ wolfhagen@aluteam.de 🌐 www.aluteam.de

